



FIM Cross-Country Rallies World Championship

Oriol Gallemí i Rovira, MSc. MEng.
FIM e-Power Technical Director



RIDE
WITH US!

Events year 2011

Cross country rallies

[403/05 Pharaon's Rally 2011](#)

[403/03 Sardegna Rally Race 2011](#)

[403/02 Rallye de Tunisie 2011](#)

[403/01 Abu Dhabi Desert Challenge 2011](#)

International events

890/01-27/12/11-08/01/12 [Africa Eco Race Rallye TT](#) Maroc Mauritanie Sénégal

890/02-01/01/12-15/01/12 [Dakar Argentina Chile Rallye TT](#) Argentine-Chili

890/03-02/06/12-02/06/12 [56ème Rallye Int. De la Police Liègeoise](#) Liège



**RIDE
WITH US!**

Definition

A Cross-Country Rally is a sporting event staged over varied terrain and is intended to prove the skill and endurance of riders, and the reliability of their machines.



**RIDE
WITH US!**

Who does what

Organiser

- Provide support to hold the event (+insurance, fuel)
- Coordinate event operational tasks (log)

FIM

- International jury - sanctioning
- Technical rules deployment

Teams

- Race and self support



Categories (minimum)

1. World Championship 450cc riders & manufacturers
 2. FIM Prize Rallies World Cup - Quad riders
 3. FIM Prize Rallies World Cup - Women riders
 4. FIM Prize Open Trophy - All riders
- All motorcycles must fulfill the national requirements of their registration country and the event country
 - Refuelling: max 250km, 15min minimum stop
 - Start motorcycles, then cars
 - Technical classification in Classes, categories & groups



Event characteristics

- Last between 4 and 20 days
- Minimum time of 20 days between races
- Combined with FIA XC-WC and organisers' support races
- Official itinerary is kept secret until roadbooks deliver
- Validation of waypoints must be chronological
- Validation will be within WPM 200m radius
- GPS are capped out of 3km from WPM's (compass)
- Emergencies: 5555 (+6h penalty), WPM (+3h)



Road book

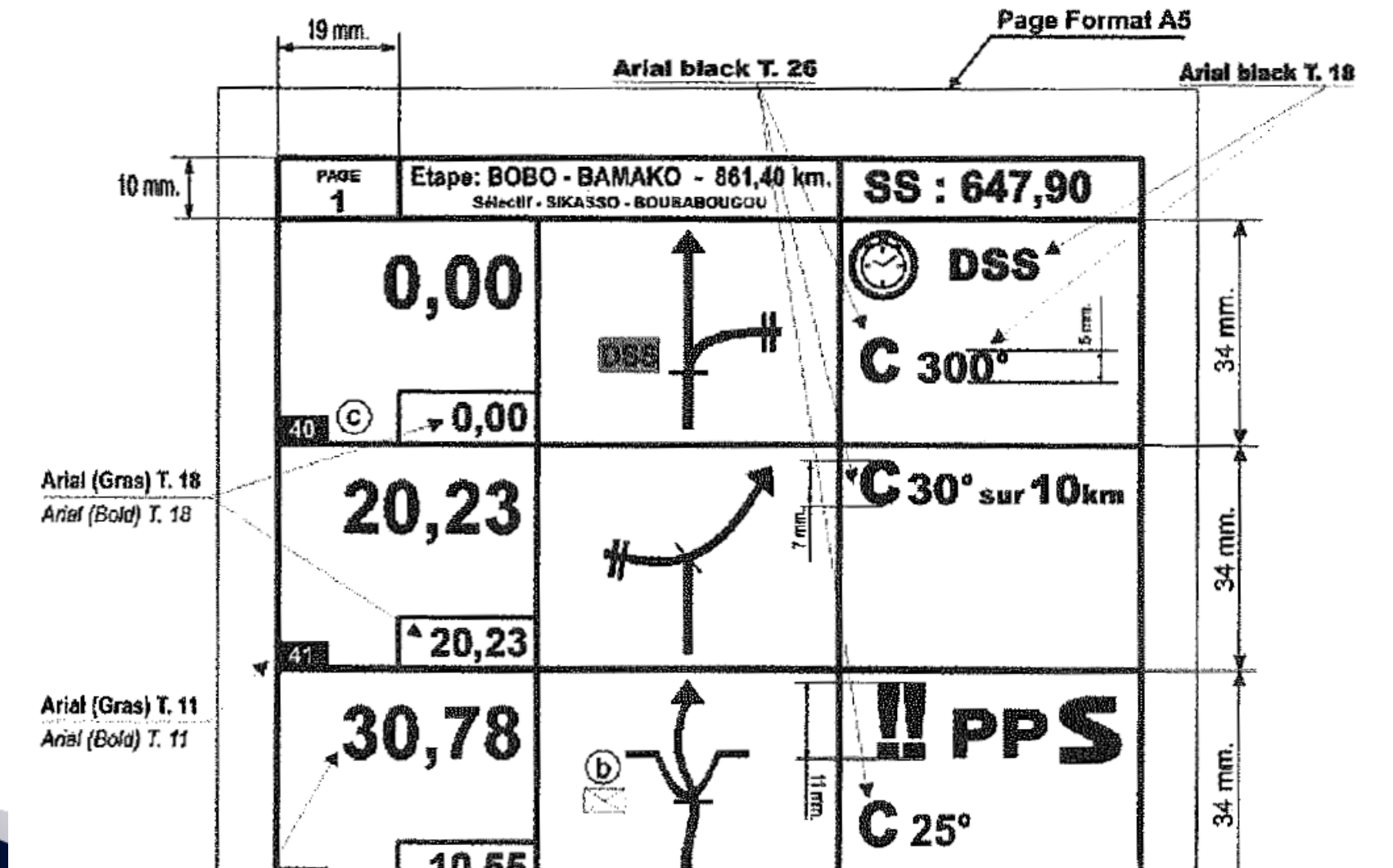

**RIDE
WITH US!**

Route

- Legs (<700km)
 - Selective sections (<600km, not night start)
 - Road sections
- Time lapse of
 - 6h after 1 leg
 - 18h after 10 legs
 - 18h after 6000km
- Super Special Stage
 - Selective section from 2 to 10km

ENVIRONMENTAL POLICIES ENFORCED!!!!



**RIDE
WITH US!**

Safety

Each vehicle and helicopter must have at least the following equipment:

- A Satellite Tracking System
- 1 VHF radio
- 1 satellite phone

Each rider must provide himself with a first-aid medical kit composed of:

- A water disinfectant for 40 litres (hydrochlorazone or micropure)
- Eye lotion (Boroclarine, Piroftal or equivalent)
- An antalgic (Aspirine, analgesic or equivalent)
- Two anti-diarrhoeic (Immodium, Ercéfuryl, Bimixin or equivalent)
- Antibiotic (Oracilline, Totapen or equivalent)
- Unguent, disinfecting compresses, two bandages, plasters, 5 safety pins
- One skin disinfectant (Betadine or equivalent)
- One sun screen for skin and lips
- Vitamin C tablets
- Salt tablets (Enervit or Nergisport sodium or similar)
- A soothing cream (Biafine)



Safety

Compulsory survival equipment, for the Rallies held in a desert environment:

- Each motorcycle: 3L of drinking water
- A soft water tank of minimum 2 litres carried by the rider
- One survival supply of rations
- A pocket lamp, if possible flashing
- An emergency mirror
- One compass besides that which is on board the motorbike
- A lighter
- A general map of the country crossed (Michelin type)
- One aluminium survival blanket (about 2 m x 1 m) serving as an isothermal covering
- An earth to sun signal
- 3 red hand-held smoke flares
- A klaxon of the Vehicle to Vehicle Alarm system
- A Satellite Tracking System
- A single GPS
- A distress beacon



Thanks for your attention

More info at www.fim-live.com

Oriol Gallemí i Rovira

FIM e-Power Technical Director

oriol.gallemi@a3e.org



**RIDE
WITH US!**



La moto: un estil de vida

Oriol Puig Bultó
Dr. Enginyer Industrial
President de la FIM-CTI
Retirat de Derbi i Bultaco



**RIDE
WITH US!**

L'experiència

Primer Motocross
Bultaco Tralla 101
125cc modificada,
octubre 1959



Sherpa S 125-175- 200cc 1959 a 1964

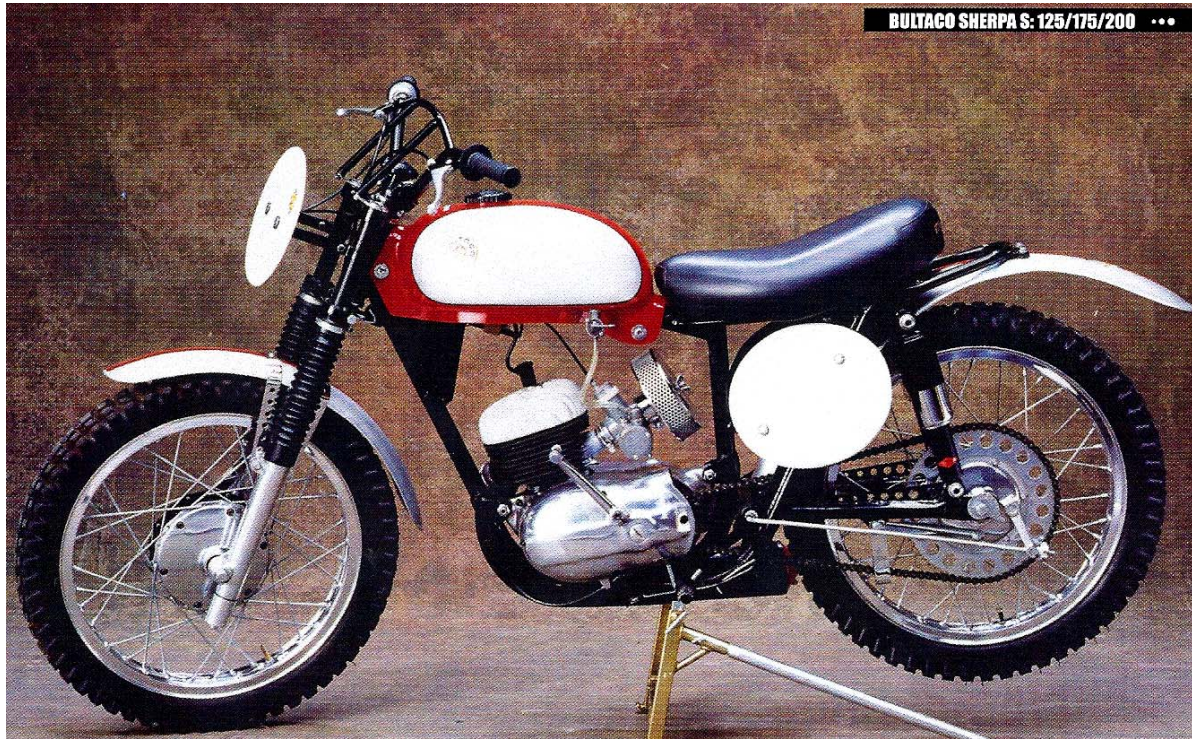



Bultaco Metisse 250cc 1965-1966



**RIDE
WITH US!**



Pursang Mk2 250cc 1967-68



RIDE
WITH US!



Pursang Mk10 370cc 1977



RIDE
WITH US!

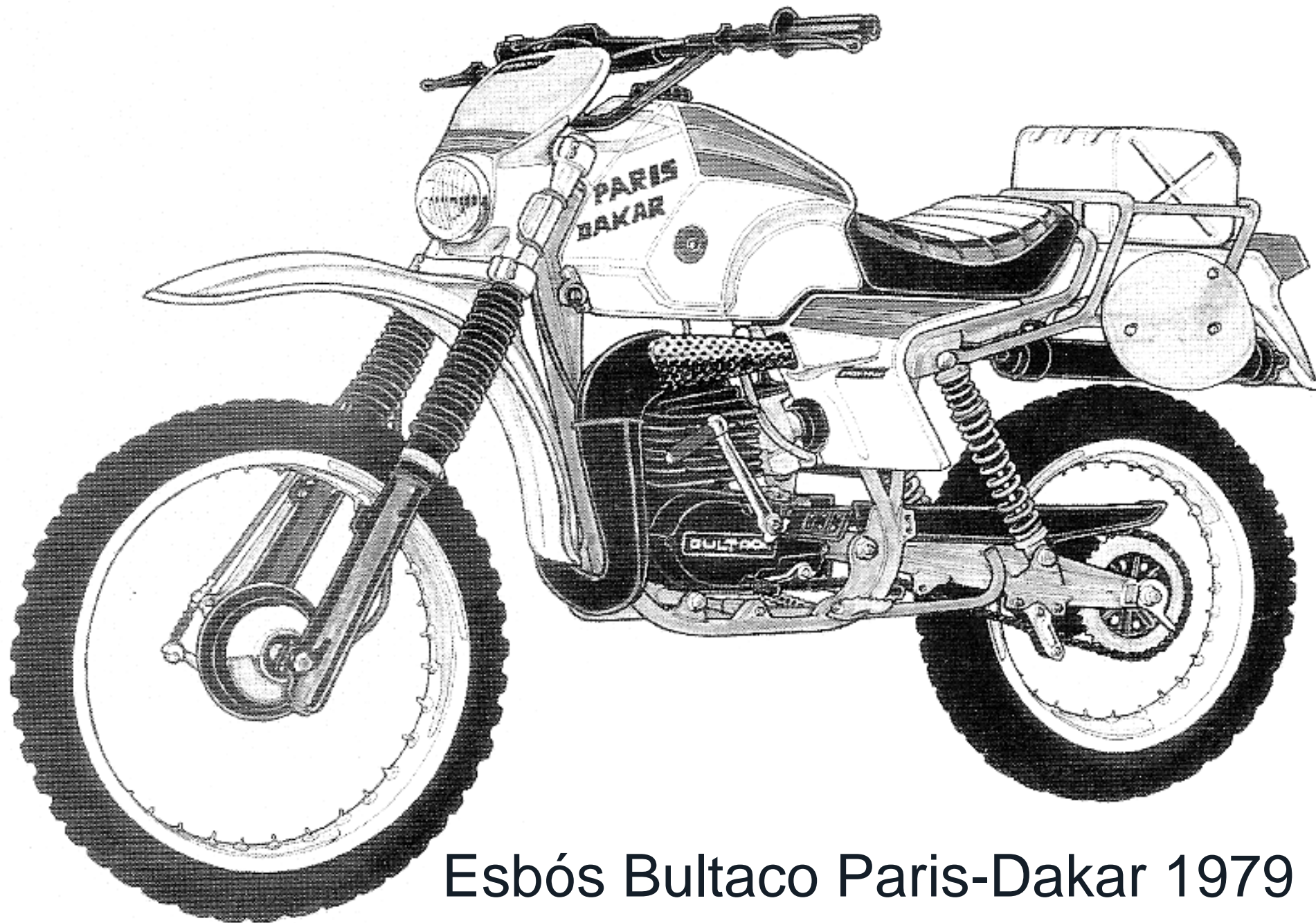

Esbós Bultaco Paris-Dakar 1979



RIDE
WITH US!

Gràcies per la vostra atenció

Oriol Puig Bultó
President FIM-CTI



**RIDE
WITH US!**